

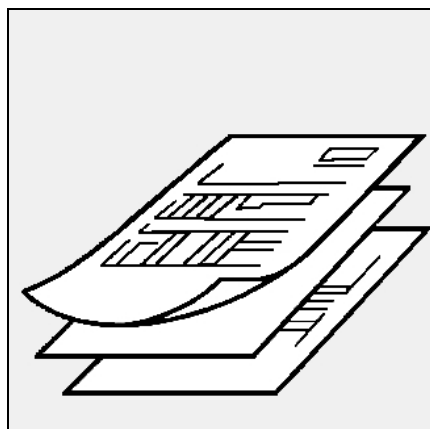

## C60 GX507/8



**Données techniques**  
**Brûleurs gaz**..... 2-8

FR

**Dati tecnici**  
**Bruciatori di gas** ..... 2-8

IT



**Datos técnicos**  
**Quemadores de gas** ..... 2-8

ES

**Technical data**  
**Gas burners** ..... 2-8

EN

**Technische Daten**  
**Gasbrenner** ..... 2-8

DE



**Технические характеристики**  
**Газовые горелки**..... 2-8

RU

**Pièces de rechange**  
**Pezzi di ricambio**  
**Piezas de recambio**  
**Spare parts list**  
**Ersatzteilliste**  
**Запчасти**..... 9-17



**Schémas électrique et hydraulique**  
**Schemi elettrico e idraulico**  
**Esquema eléctrico y hidráulico**  
**Electric and hydraulic diagrams**  
**Elektro- und Hydraulikschema**  
**Электрические и гидравлические схемы**19-23



**Principaux composants / Caractéristiques d'utilisation**  
**Componenti principali / Caratteristiche d'impiego**  
**Componentes principales / Características de utilización**  
**Main components / Characteristics of use**  
**Wichtigste Komponenten / Betriebsdaten**  
**Основные комплектующие / Рабочие характеристики**

---

**Principaux composants:**

- Coffret de commande et sécurité: SG 513
- Détecteur de flamme: sonde d'ionisation
- Variateur de vitesse du moteur de ventilation: ATV11HU18M2E
- Moteur de ventilation: 750W, 230V triphasé, 50-60Hz, 2880/3490tr/min
- Turbine du ventilateur: Ø180 x 75
- Transformateur d'allumage: 1x11kV
- Commande du volet d'air: servomoteur STA 19
- Manostat d'air: LGW 10 A2

**Componenti principali**

- Programmatore di comando: SG 513.
- Rilevatore di fiamma: sonda di ionizzazione
- Variatore di velocità del motore di ventilazione: ATV11HU18ME2
- Motore del ventilatore: 750W, 230V trifase 50-60Hz, 2880/3490giri/min
- Turbina del ventilatore: Ø180 x 75
- Trasformatore d'accensione: 1x11kV
- Comando serranda aria: servomotore STA 19
- Manostato dell'aria: LGW 10 A2

**Principales componentes**

- Cajetín de control y seguridad: SG 513
- Detector de llama: sonda de ionización
- Variador de velocidad del motor de ventilación: ATV11HU18M2E
- Motor de ventilación: 750W, 230V trifásica 50-60Hz, 2880/3490t/min
- Turbina del ventilador: Ø180 x 75
- Transformador de encendido: 1x11kV
- Control trampilla de aire: servomotor STA 19
- Manostato de aire: LGW 10 A2

**Caractéristiques d'utilisation**

Température ambiante:  
- d'utilisation: -5 ... 40°C  
- de stockage: - 20 ...70°C  
Tension / Fréquence:  
- 230 VAC -15...+10% - 50Hz $\pm$ 1%  
monophasé  
Degré de protection: IP 21

**Caratteristiche d'impiego**

Temperatura ambiente :  
- d'utilizzazione : -5 ...40° C  
- di stoccaggio : -20 ...70° C  
Tensione / Frequenza :  
- 230 VAC -15...+10% - 50 Hz $\pm$ 1%  
monofase  
Grado di protezione : IP 21

**Características de utilización**

Temperatura ambiente :  
- de utilización : - 5 ...40° C  
- de almacenamiento : - 20 ...70° C  
Tensión eléctrica / Frecuencia :  
- 230 VAC -15...+10% - 50 Hz $\pm$ 1%  
monofásico  
Grado de protección : IP 21

**Principaux composants / Caractéristiques d'utilisation**  
**Componenti principali / Caratteristiche d'impiego**  
**Componentes principales / Características de utilización**  
**Main components / Characteristics of use**  
**Wichtigste Komponenten / Betriebsdaten**  
**Основные комплектующие / Рабочие характеристики**

---

**Main components**

- Control unit :  
SG 513
- Flame detector :  
ionization probe
- Fan motor variable speed drive:  
ATV11HU18M2E
- Fan motor:  
750W, 230V three-phase  
50-60Hz, 2880/3490rpm
- Fan turbine : Ø180 x 75
- Ignition transformer :  
1x11kV
- Air flap control :  
servomotor STA 19
- Air pressure switch:  
LGW 10 A2

**Wichtigste Komponenten:**

- Feuerungsautomat:  
SG 513
- Flammenwächter:  
Ionisationssonde
- Frequenzumrichter des Gebläse-  
motors: ATV11HU18M2E
- Gebläsemotor:  
750W, 230V dreiphasig,  
50-60Hz, 2880/3490U/min
- Lüfterrad: Ø180 x 75
- Zündtransformator:  
1x11kV
- Luftklappensteuerung:  
Stellantrieb STA 19
- Luftdruckwächter:  
LGW 10 A2

**Основные компоненты**

- Блок управления:  
SG513
- Детектор факела:  
ионизационный зонд
- Регулируемый привод двигателя  
воздуходувки: ATV11HU18M2E
- Двигатель воздуходувки:  
750Вт, 230 В три фазы  
50-60 Гц, 2880/3490 об./мин.
- Турбина воздуходувки: Ø 180 x 75
- Трансформатор розжига:  
1 x 11 кВ
- Управление воздушной заслонкой:  
серводвигатель STA 19
- Реле давления воздуха:  
LGW 10 A2

**Characteristics of use**

Ambient temperature :  
- for use : - 5... 40° C  
- for storage : - 20... 70° C  
Voltage / Frequency :  
- 230 VAC -15...+10% - 50 Hz $\pm$ 1%  
single-phase  
Protection level : IP 21

**Betriebsdaten**

Umgebungstemperatur :  
- Betriebstemperatur : -5...40°C  
- Lagerungstemperatur : -20...70°C  
Spannung/Frequenz :  
- 230 VAC -15...+10% - 50 Hz $\pm$ 1%  
einphasig  
Schutzart : IP 21

**Рабочие характеристики**

Температура окружающего воздуха:  
- при эксплуатации: -5 ... 40 °C  
- при хранении: - 20 ... 70 °C  
Напряжение/Частота:  
- 230 В переменного тока -15 ...+10 %  
- 50 Гц $\pm$ 1% однофазный  
Уровень электрозащиты: IP 21

**Courbes de puissance**  
**Curve di potenza**  
**Diagramas de potencia**  
**Power graphs**  
**Arbeitsfelder**  
**Рабочие кривые**

**Composition de la rampe gaz**  
**Composizione della rampa gas**  
**Composición de la rampa de gas**  
**Gas manifold composition**  
**Zusammensetzung der Gasarmatur**  
**Состав газовой рампы**

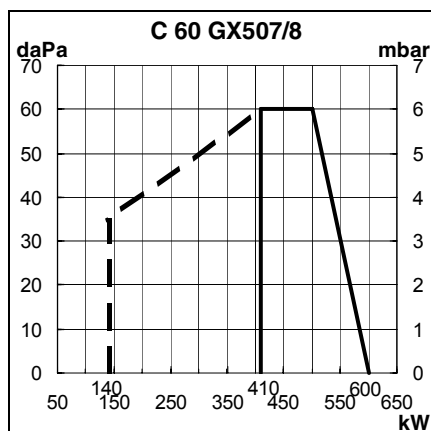

Brûleur Bruciatore Queimador Burner Brenner Горелка	P max P макс.	Gaz Gas Gas Gas Gas Газ	P gaz P Gas P Gas P Gas P Газ	Vanne Valvola Válvula Valve Ventil Клапан		Filtre Filtro Filtro Filter Filter Фильтр			Manostat Manostato Manóstato Press. Switch Druckwächter Регулятор
				MB VEF...	Ø bride Ø flangia Ø brida Ø flange Ø Flansch Ø фланца Rp	Intégré Incorp. Integrado Integrated Interner внутр. FI	extérieur externo exterior external externer наружн. Rp	poche tasca bolsa pocket Taschen карман. FP	
C 60	600	G20	300	407	3/4"	FI	1	150A5	
		G25	300						
		G31	148						
		G31	37	412	1" 1/4	FI			
		G20	20	420	1" 1/2				FP
		G25	25						

Type Tipo Tipo Tipo Type Art Тип	Groupe Gruppo Grupo Group Gruppe Группа	Pression de distribution Pressione di distribuzione Presión de distribución Distribution pressure Eingangsdruk Давление на входе			Hi à 0°C et 1013 mbar Hi a 0°C e 1013 mbar Hi à 0° C y 1013 mbar Hi at 0°C and 1013 mbar Hi bei 0°C und 1013 mbar Hi при 0°C и 1013 мбар		Gaz Gas Gas Gas Gas Газ
		Pn mbar мбар	Pmin mbar мбар	Pmax mbar мбар	min (kWh/m <sup>3</sup> ) (кВтч/м <sup>3</sup> )	max (kWh/m <sup>3</sup> ) (кВтч/м <sup>3</sup> )	
Gaz H Gas H	2H	20 300	17 240	25 360	9,5	11,5	G20
Gaz L Gas L	2L	25 300	20 240	30 360	8,5	9,5	G25
Gaz P Gas P	3P	37 148	25 120	45 180	24,5	26,5	G31

Puisance kW Potenza kW Potencia kW Power kW Leistung kW Мощность кВт	C60GX507/8			
	min мин.	G20 p20/p300 max макс.	G25 p25/p300 max макс.	G31 p37/p148 max макс.
Brûleur (kW)	410	600	600	600
Min. allumage (kW)	140	---	---	---
Générateur (kW)	377	552	552	552
Débit nominal réel de gaz à 15°C et 10.13 mbar				
<b>Naturel groupe H</b> Hi =9,45	m <sup>3</sup> /h (kWh/m <sup>3</sup> )	43,4 63,5	---	---
<b>Naturel groupe L</b> Hi =8,13	m <sup>3</sup> /h (kWh/m <sup>3</sup> )	50,4	73,8	---
<b>Propane P</b> Hi =24,44	m <sup>3</sup> /h (kWh/m <sup>3</sup> )	16,8	---	24,5
Мasse volumique kg/m <sup>3</sup> = 1,98				
Bruciatore (kW)	410	600	600	600
Min. accensione (kW)	140	---	---	---
Generatore (kW)	377	552	552	552
Portata nominale eff. di gas a 15°C e 10.13 mbar				
<b>Naturale gruppo H</b> Hi =9,45	m <sup>3</sup> /h (kWh/m <sup>3</sup> )	43,4 63,5	---	---
<b>Naturale gruppo L</b> Hi =8,13	m <sup>3</sup> /h (kWh/m <sup>3</sup> )	50,4	73,8	---
<b>Propano P</b> Hi =24,44	m <sup>3</sup> /h (kWh/m <sup>3</sup> )	16,8	---	24,5
Масса volumica kg/m <sup>3</sup> = 1,98				
Quegador (kW)	410	600	600	600
Min. encendido (kW)	140	---	---	---
Generador (kW)	377	552	552	552
Caudal nominal real de gas a 15°C y 10.13 mbar				
<b>Natural grupo H</b> Hi =9,45	m <sup>3</sup> /h (kWh/m <sup>3</sup> )	43,4 63,5	---	---
<b>Natural grupo L</b> Hi =8,13	m <sup>3</sup> /h (kWh/m <sup>3</sup> )	50,4	73,8	---
<b>Propano P</b> Hi =24,44	m <sup>3</sup> /h (kWh/m <sup>3</sup> )	16,8	---	24,5
Densidad kg/m <sup>3</sup> = 1,98				
Burner (kW)	410	600	600	600
Min. ignition (kW)	140	---	---	---
Generator (kW)	377	552	552	552
Actual gas flow rate at 15°C and 10.13 mbar				
<b>Natural group H</b> Hi =9.45	m <sup>3</sup> /h (kWh/m <sup>3</sup> )	43,4 63,5	---	---
<b>Natural group L</b> Hi =8.13	m <sup>3</sup> /h (kWh/m <sup>3</sup> )	50,4	73,8	---
<b>Propane P</b> Hi =24.44	m <sup>3</sup> /h (kWh/m <sup>3</sup> )	16,8	---	24,5
Voluminal mass kg/m <sup>3</sup> = 1,98				
Brenner (kW)	410	600	600	600
Min. Zündung (kW)	140	---	---	---
Kessel (kW)	377	552	552	552
Effektiver Gasdurchsatz bei 15°C und 10.13 mbar				
<b>Erdgas Gruppe H</b> Hi =9,45	m <sup>3</sup> /h (kWh/m <sup>3</sup> )	43,4 63,5	---	---
<b>Erdgas Gruppe L</b> Hi =8,13	m <sup>3</sup> /h (kWh/m <sup>3</sup> )	50,4	73,8	---
<b>Flüssiggas P</b> Hi =24,44	m <sup>3</sup> /h (kWh/m <sup>3</sup> )	16,8	---	24,5
Dichte kg/m <sup>3</sup> = 1,98				
Горелка (кВт)	410	600	600	600
Мин. Мощность розжига (кВт)	140	---	---	---
Котел (кВт)	377	552	552	552
Эффект. расход газа при 15°C				
<b>Природный газ группы H</b> Hi =9,45	m <sup>3</sup> /ч (кВтч/м <sup>3</sup> )	43,4 63,5	---	---
<b>Природный газ группы L</b>	m <sup>3</sup> /ч	50,4	73,8	---

**Encombrement Dimensions  
Dimensioni d'ingombro  
Dimensiones Medidas  
Space requirements and dimensions  
Maßbild und Abmessungen  
Занимаемый объем Размеры**

p37-148-300

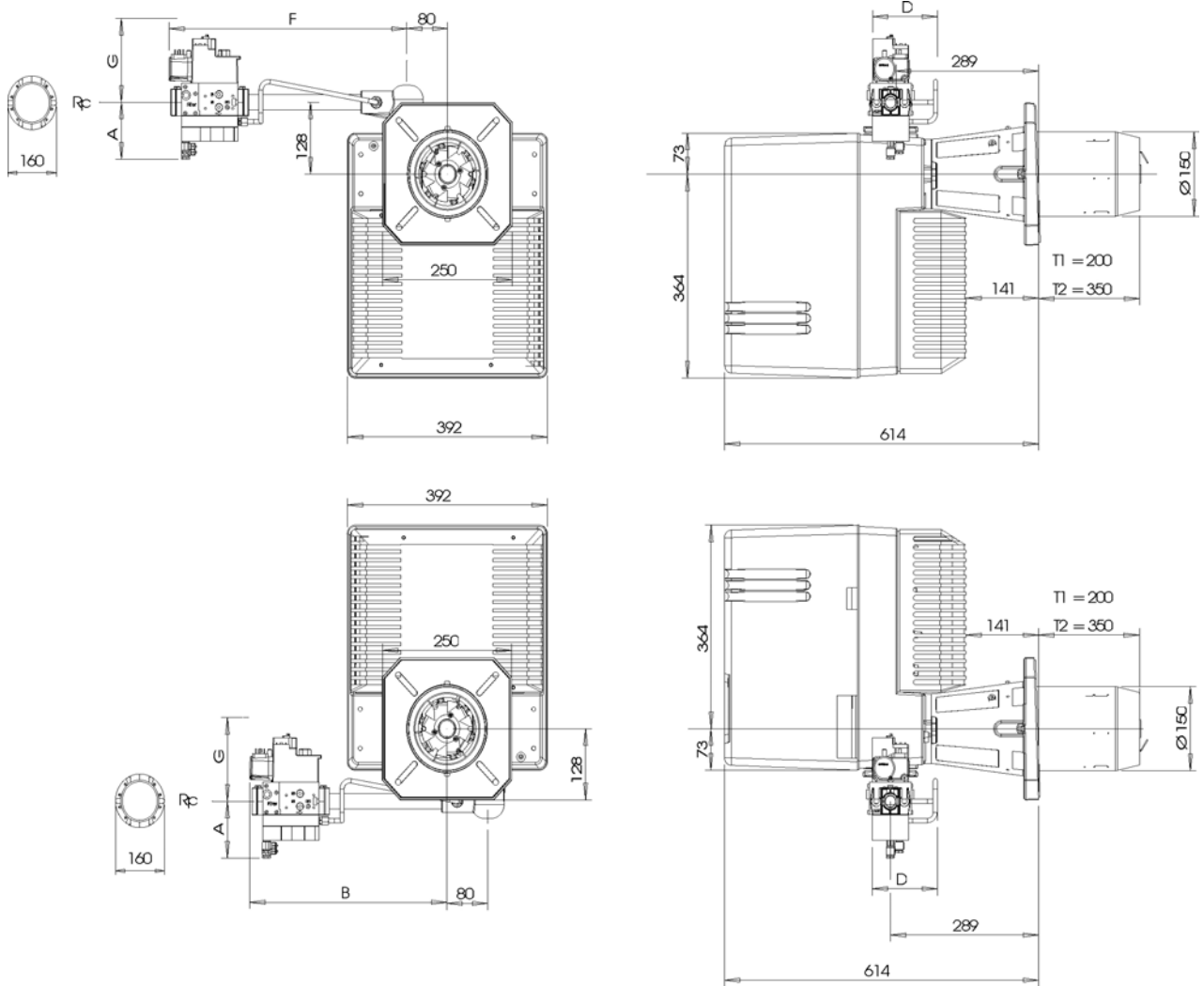

	A	B	D	F	G	Rp
p148-300	105	390	125	470	150	3/4"
p37	100	420	145	500	170	1" 1/4

**Pour l'implantation volute en bas :**

lire les informations complémentaires au paragraphe "Installation" montage du brûleur.

**Per l'installazione con la voluta verso il basso:**

leggere le informazioni complementari al paragrafo "Installazione", montaggio del bruciatore.

**Para colocar la voluta hacia abajo :**

leer las informaciones complementarias en el párrafo "Instalación" montaje del quemador.

**For setting-up with the spiral at bottom :**

read the additional information in the "Assembly" paragraph of the burner installation instructions.

**Für den Einbau mit nach unten gerichtetem Lüfterrad :**

Die ergänzenden Informationen des Kapitels "Installation" "Montage des Brenners beachten.

**При установке спирали снизу:**

см. дополнительную информацию в разделе "Установка" Монтаж горелки.

**Encombrement Dimensions  
Dimensioni d'ingombro  
Dimensiones Medidas  
Space requirements and dimensions  
Maßbild und Abmessungen**

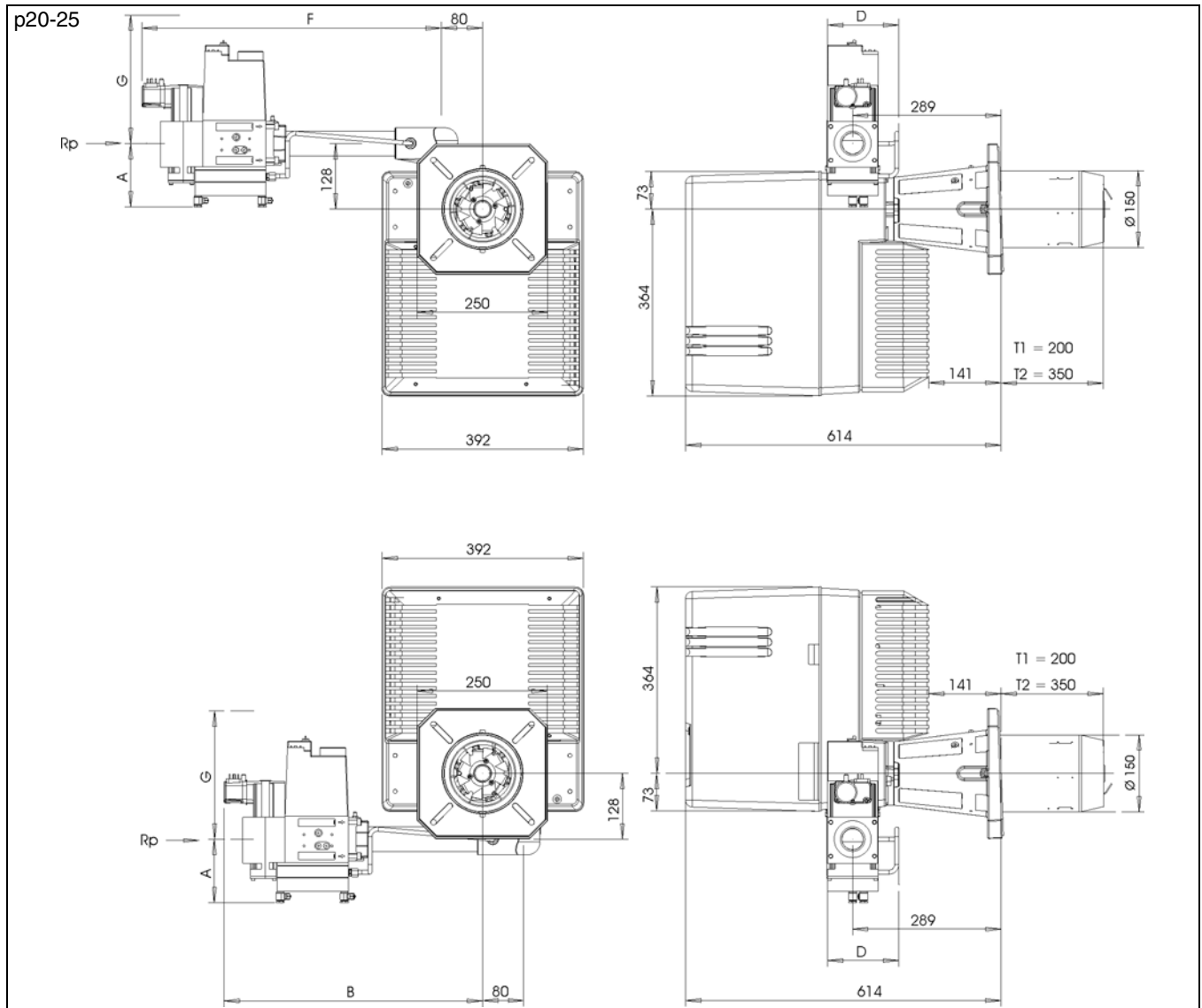

A	B	D	F	G	Rp
125	500	145	580	220	1" 1/2

**Pour l'implantation volute en bas :**

lire les informations complémentaires au paragraphe "Installation" montage du brûleur.

**Per l'installazione con la voluta verso il basso:**

leggere le informazioni complementari al paragrafo "Installazione", montaggio del bruciatore.

**Para colocar la voluta hacia abajo :**

leer las informaciones complementarias en el párrafo "Instalación" montaje del quemador.

**For setting-up with the spiral at bottom :**

read the additional information in the "Assembly" paragraph of the burner installation instructions.

**Für den Einbau mit nach unten gerichtetem Lüfterrad :**

Die ergänzenden Informationen des Kapitels "Installation" "Montage des Brenners beachten.

**При установке спирали снизу:**

см. дополнительную информацию в разделе "Установка" Монтаж горелки.

# Encombremet Dimensions

## Dimensioni d'ingombro

## Dimensiones Medidas

## Space requirements and dimensions

## Maßbild und Abmessungen

## Занимаемый объем Размеры

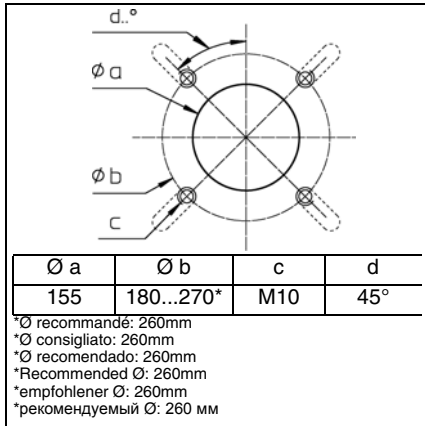

### Encombremet et dimensions

Respecter une distance libre minimum de 0,6 mètre de chaque côté du brûleur pour permettre les opérations de maintenance.

### Ventilation chaufferie

Le volume d'air neuf requis est de 1,2 m<sup>3</sup>/kWh produit au brûleur.

### Rampe gaz

S'implante uniquement à l'horizontale à **droite** ou à gauche.

### Dimensioni d'ingombro

Lasciare uno spazio libero minimo di 0,6 metri su ogni lato del bruciatore per consentire le operazioni di manutenzione.

### Ventilazione locale caldaia

La portata dell'aria di ricambio del locale deve essere almeno di 1,2 m<sup>3</sup>/kWh bruciatore.

### Rampa gas

Deve essere installata unicamente in orizzontale a **destra** o a sinistra.

### Dimensiones y medidas

Respetar una distancia libre mínima de 0,6 metros a ambos lados del quemador para permitir las operaciones de mantenimiento.

### Ventilación calentador

El volumen de aire nuevo requerido es de 1,2 m<sup>3</sup>/kWh producido en el quemador.

### Rampa de gas

Sólo se coloca en horizontal a la **derecha** o a la izquierda.

### Space requirements and dimensions

Leave a space of at least 0.6 metres on each side of the burner for maintenance purposes.

### Boiler-house ventilation

Volume of fresh air required is 1.2 m<sup>3</sup>/kWh produced at the burner.

### Gas manifold

Can only be installed horizontally, on the **right** or on the left.

### Maßbild und Abmessungen

Für Servicearbeiten ist ein freier Abstand von min. 0,6 m auf jeder Seite des Brenners sicherzustellen.

### Heizraumbelüftung

Die nötige Frischluftzufuhr beträgt 1,2 m<sup>3</sup>/kWh am Brenner.

### Gasarmaturgruppe

Montage waagrecht **rechts** oder links möglich.

### Занимаемый объем и размеры

Обеспечьте свободное пространство минимум 0,6 м с каждой стороны горелки для осуществления работ по ее обслуживанию.

### Вентиляция котла

Требуемый объем приточного воздуха для производительности горелки 1,2 м<sup>3</sup>/кВтч.

### Газовая рампа

Устанавливается только в горизонтальном положении с **правой** или левой стороны.



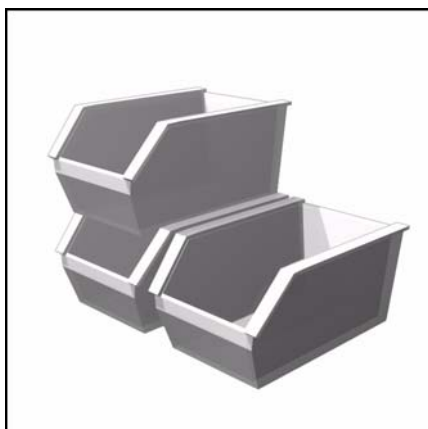

**Pièces de rechange**  
**Pezzi di ricambio**  
**Piezas de recambio**  
**Spare parts list**  
**Ersatzteilliste**  
**Запчасти**

**C60 GX507/8**



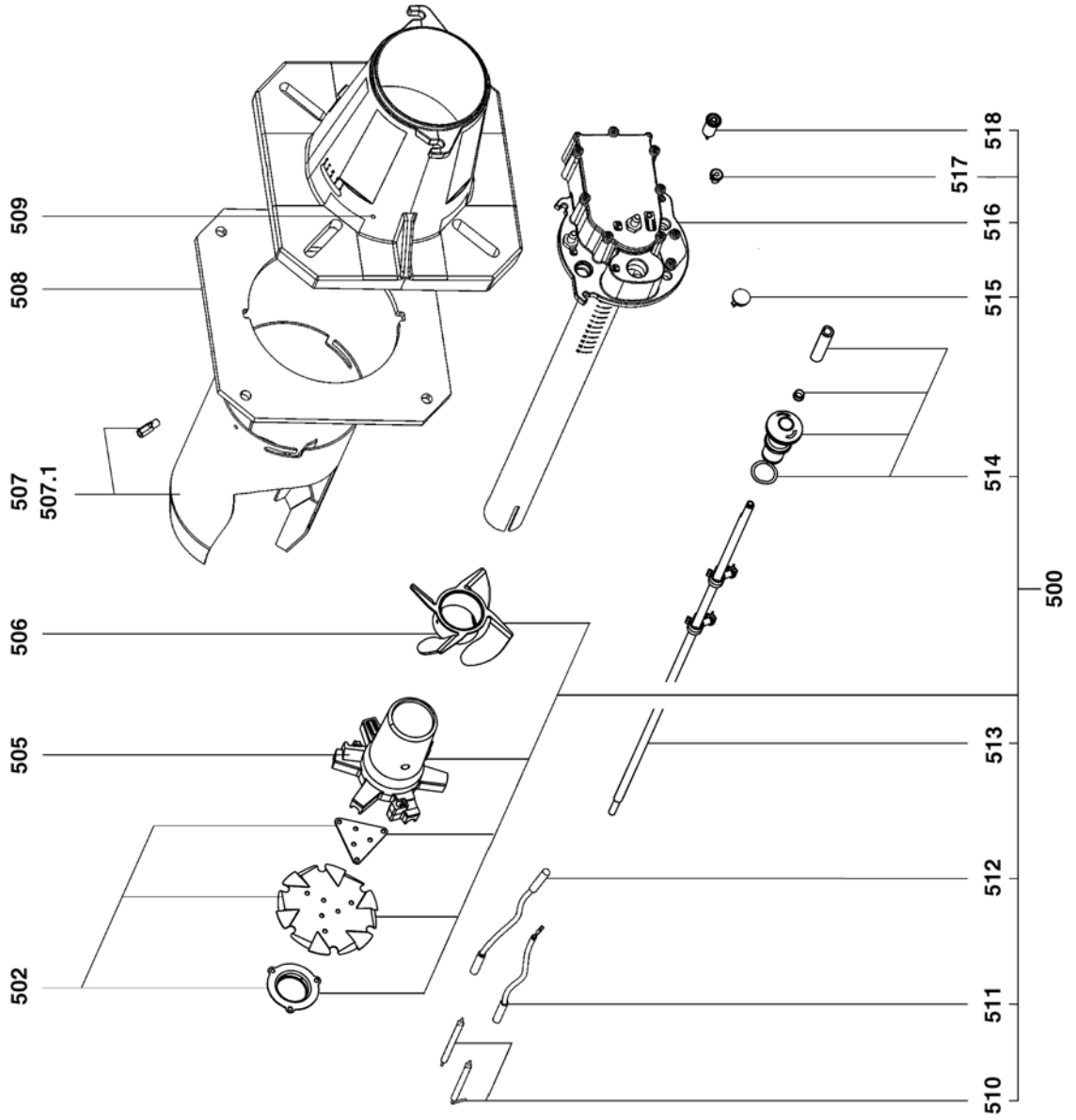

Pos.	Désignation	Denominazione	Designación	Description	Bezeichnung	Назначение	N° Art.
500	Ligne gaz complète C60 GX 507/8 T1 T2	Linea gas completa	Linea gas	Complete gas line	Lanzengaskopf	Газовая линия к соплу	
502	Kit défil. + diffus. + obturateur	Set deflectore + diffusore + otturatore	Kit de defl. + diffus. + obturador	Set turbulator+ diffusor + shutter	Set Defl. + Diffus. + Verschluss	Комплект дефлектор + диффузор + заслонка	13 016 251
505	Etoile répat. gaz	Ripartitore gas	Estrella gas	Star gas head	Sterngaskopf	Звездочка распределения газа	
506	Turbulateur	Turbulatore	Turbulador	Helic.turbulator	Stauscheibe	Турбулизатор	
507	Embout + vis	Imbuto + viti	Cañon + Tornillo	Blast tube + screws	Brennerrohr + Schrauben	Комплект + винтов	
	C60 x 268 x 418						13 015 879 13 015 881
507.1	Levier rotation embout	Leva rotazione imbuto	Palanca de rotación de la contera	Blast tube rotat. lever	Hebel Flammrohrdrehung	Рычаг поворота насадки	
508	Joint/façade chaudière	Guarnizione/ sportello della caldaia	Junta/frontal de la caldera	Flange klingerit	Dichtung/ Kesselanschlußplatte	Уплотнительная прокладка/внешняя сторона котла	13 016 214
509	Vis M6 (à gauche) fixation embout 3x	Vite M6 (alla sinistra) fissazione imbuto	3 tornillos M6 (a izquierda) para la fijación de la contera	Screw M6 (left hand thread) flame tube	Schraube M6 (linksgewinde) Befestigung Flammrohr 3x	Винт М6 (слева) крепления насадки 3х	13 016 777
510	Sonde d'ionisation + electrode allu.	Sonda di ionizzazione + elettrodo di accens.	Sonda de ionización + electrodo de encendido	Ionisation probe + ignition electrode	Ionisationssonde + Zündelektrode	ионизационный + запальный электрод	13 015 841
511	Câble d'ionisation L.700	Cavo di ionizzazione	Cable sonda de ionización	Ionisation cable	Ionisationskabel	Кабель ионизационного	13 015 625
512	Câble d'allumage L.1050	Cavo accensione	Cable de encendido	Ignition lead	Zündkabel	Кабель розжига	13 015 610
513	Tige de réglage Lg. 646 T1 Lg. 796 T2	Asta di regolazione	Varilla de ajuste	Adjust linkage	Regulierstange	Регулировочный стержень	
514	Bouton de cde ligne gaz	Bottone di comando linea porta gas	Botón de mando de la línea de gas	Adjust knob	Bedienungsknopf Lanzengaskopf	Кнопка управления газовым трактом	13 016 854
515	Voyant de flamme	Spia di fiamma	Testigo de flama	Sight glas	Schauglas	Глазок для контроля пламени	
516	Coude gaz T1 Lg. 496 T2 Lg. 646	Curva gas	Codo gas	Lance gas head	Messnippel-Winkel Gas	колено газ	
517	Passé fil	Passacavo	Capuchón de goma	Rubber funnel	Tülle	Насадка	
518	Douille BI 6.3	Manicotto	Casquillo	Measure socket	Hülse	Втулка	



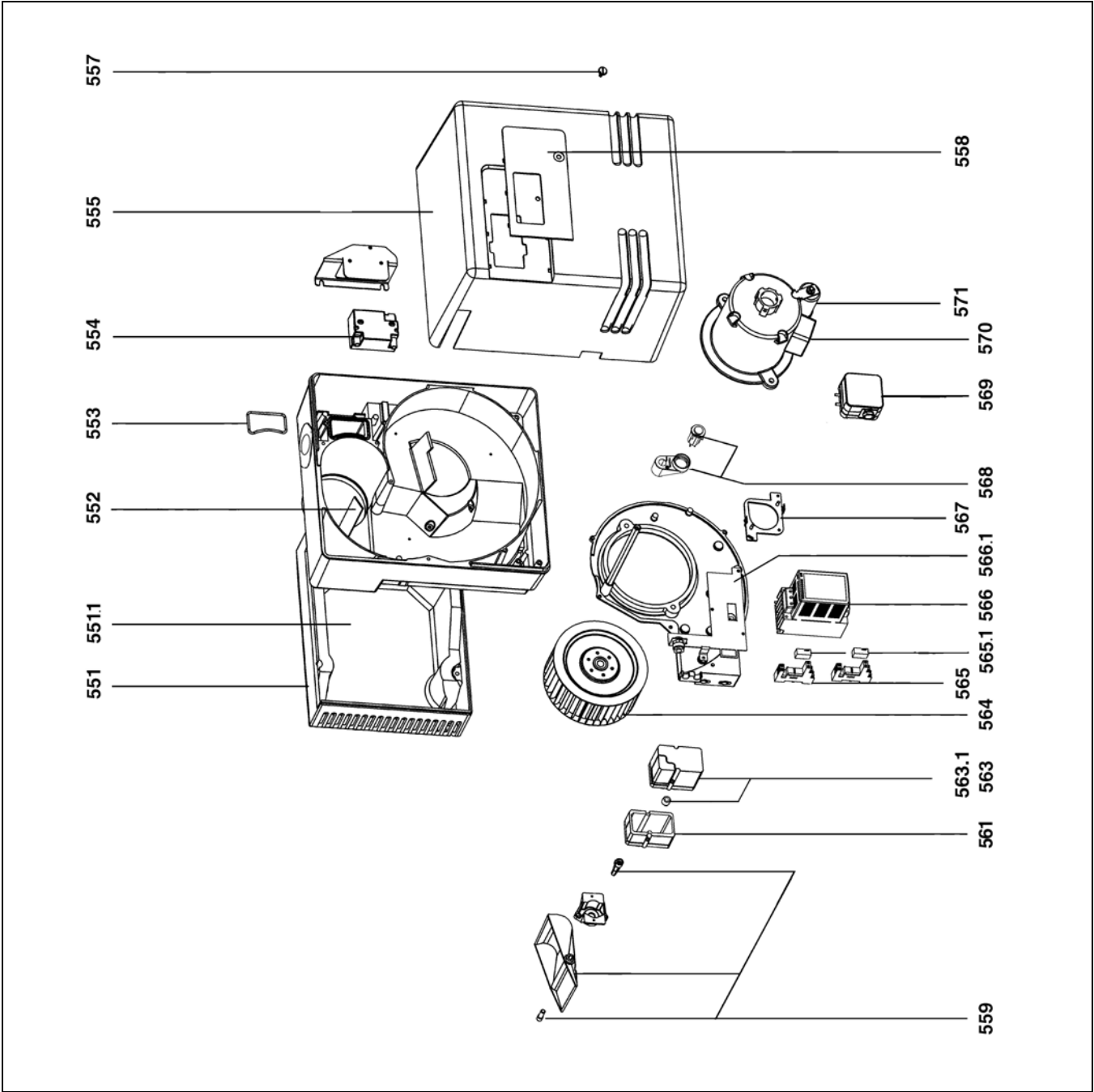

Pos.	Désignation	Denominazione	Designación	Description	Bezeichnung	Назначение	N° Art.
550	Corps	Corpo	Bloque	Body	Körper	Корпус	
551	Boîte à air	Scatola d'aria	Caja de aire	Air damper	Luftkasten	Воздушная коробка	
552	Guide d'air	Guida d'aria	Guía de aire	Air guiding piece	Luftführung	Воздуховод	
553	Joint O'Ring / raccord. gaz	O'Ring / raccordo gas	Junta O'Ring / conex. de gas	Flange / gas connection	O'Ring / Gasanschluss	Кольцевой уплотнитель / газовый штуцер	
554	Transformateur EBI - 1x11KV	Trasformatore d'accensione	Transformador	Ignition transformer	Zündtrafo	Трансформатор розжига	13 016 668
555	Capot orange équipé	Coperchio arancio	Tapa naranja	Orange cover cpl.	Schützhaube	Оранжевый кожух	13 015 653
557	Vis / capot	Vite / coperchio	Tornillo / tapa	Oval head screw	Befestigungsschraube	Крепежный винт	13 016 776
558	Plaque frontale	Marchio frontale	Placa frontal	Front plate	Beschriftungsplatte	Лицевая панель	13 016 399
559	Volet air + axes	Serranda aria + assi	Trampilla de aire + ejes	Air flap + axes	Luftklappen + Achsen	Воздушная заслонка + стержни	13 016 780
560	Support servomoteur	Supporto servomotore	Soporte del servomotor	Servomotor stand	Halter für Stellantrieb	Опора серводвигателя	
561	Potentiomètre gigogne	Potenziometro	Potenciómetro encajable	Transcription potentiometer	Stellpotentiometer	Телескопический потенциометр (датчик положения)	13 011 107
563	Servomoteur air C60 GX 507/8 STA 19	Servomotore aria	Servomotor aire	Servomotor air	Servomotor Luft	Воздушная серводвигатель	13 016 568
563.1	Bague de renfort	Piastra di rinforzo	Anillo de refuerzo	Reinforcement ring	Verstärkungsring	Кольцо жесткости	13 014 901
564	Turbine Ø 180/75	Ventilatore	Turbina	Air fan	Ventilatorrad	Турбина	13 016 705
565	Support relais + Relais	Supporto relé + Relé	Soporte del relé + Relé	Relay support + relay	Relaishalter + Relais	Опора реле + реле	13 016 521
566	Variateur	Variatore	Variador	Variator	Drehzahlregler	Бесступенчатый регулятор	13 016 772
566.1	Support variateur	Supporto variatore	Soporte del variador	Variator support	Halter Drehzahlregler	Опора вариатора	13 016 602
567	Support pressostat	Supporto pressostato	Soporte del presostato	Press.contr. device stand	Halter Druckwächter	Кронштейн реле давления	
568	Ensemble réarmement	Riarmo	Conjunto de reinicio	Release system	Entriegelungsset	Узел приведения в рабочее положение	13 016 250
569	Pressostat LGW 10 A2	Pressostato	Presostato	Pressure control device	Luftdruckwächter	Реле давления	13 016 342
570	Moteur de ventilation C60	Motore di ventilazione	Motor de ventilación	Fan motor	Gebäsemotor	Двигатель воздухоудвки	13 016 378



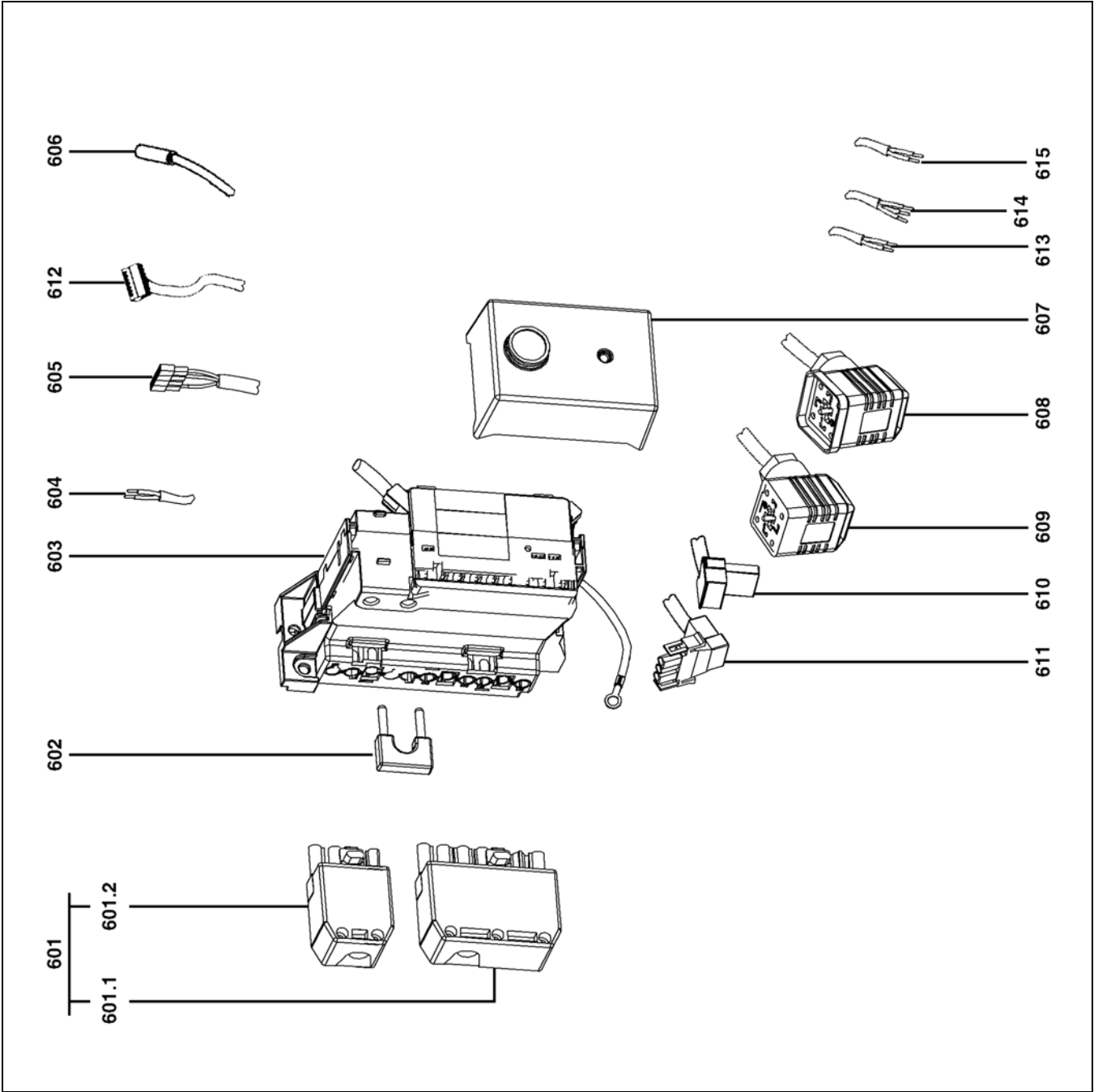

Pos.	Désignation	Denominazione	Designación	Description	Bezeichnung	Назначение	N° Art.
601	Prise Wieland 4P.+ 7P	Pres a Wieland 4P. + 7P.	Toma Wieland 4P. + 7P.	Plug Wieland 4P. + 7P.	Kabel m. Stecker 4P. + 7P.	Кабель со штекером 4P. + 7P.	13 016 496
601.1	Prise Wieland 7P.	Pres a Wieland 7P.	Toma Wieland 7P.	Plug Wieland 7P.	Kabel m. Stecker 7P.	Кабель со штекером 7P.	13 016 494
601.2	Prise Wieland 4P.	Pres a Wieland 4P.	Toma Wieland 4P.	Plug Wieland 4P.	Kabel m. Stecker 4P.	Кабель со штекером 4P.	13 016 489
602	Pont de ionisation	Punto di misura	Puente de ionización	Connection for ionisation	Verbindungsstecker	Ионизационный мост	13 016 455
603	Cassette raccord. G1/2/5	Cassetta de collegamento	Casete de conexión	Elec. connection box	Anschlußkasten mit Relaissockel ohne Kabel	Кабельная коробка для подключения различных электроприборов к горелке	13 015 684
604	Câble manostat air	Cavo manostato aria	Cable manóstatto aire	Press. cont. devise cable	Kabel Luftdruckwächter	Кабель воздушная регулятора	13 015 627
605	Câble/bouton réarmement	Cavo/riarmo	Cable torta/ cajetín de control	Cable / release	Kabel m. Stecker / Entriegelung	Кабель со штекером для кнопки сброса	13 015 613
606	Câble ionisation/cassette	Cavo ionizzazione/cassetta	Cable ionización/casete	Ionisation cable / box plug	Ionisationskabel/ Anschlußkasten	Кабель ионизационного/ кассета	13 016 467
607	Coffret SG5xx	Programmatore	Cajetín	Control unit	Feuerungsautomat	Блок безопасности	13 015 700
608	Câble vanne gaz	Cavo valvola gas	Cable válvula gas	Gas valve cable	Kabel Gasventil ohne Trenrelais	Кабель газового клапана	13 015 642
609	Câble manostat gaz	Cavo manostato gas	Cable manóstatto gas	Pressure control device cable	Kabel Gasdruckwächter	Кабель газового регулятора	13 015 628
610	Câble transfo éq. C60	Cavo trasformatore	Cavo transformador	Transformer cable	Kabel Zündtrafo	Кабель Трансформатор розжига	13 013 997
611	Câble moteur	Cavo motore	Cavo motor	Motor cable	Kabel Motor	Кабель двигатель	13 015 629
612	Câble servomoteur éq.	Cavo servomotore	Cavo servomotor	Cable 9P servomotor eq.	Kabel Servomotor	Кабель Серводвигатель	13 015 634
613	Câble relais/variateur	Cavo relé/variatore	Cable del relé/variador	Relay / variator cable	Kabel Relais/ Drehzahlregler	Кабель реле/вариатор	13 015 633
614	Câble relais/cassette	Cavo relé/cassetta	Cable del relé/casete	Elect. connection box / relay cable	Kabel Relais/Kassette	Кабель реле/кассета	13 015 632
615	Câble cassette/variateur	Cavo cassetta/variator	Cable del casete/variador	Electrical connection box / variator cable	Kabel Kasette/ Drehzahlregler	Кабель кассета/ вариатор	13 015 544



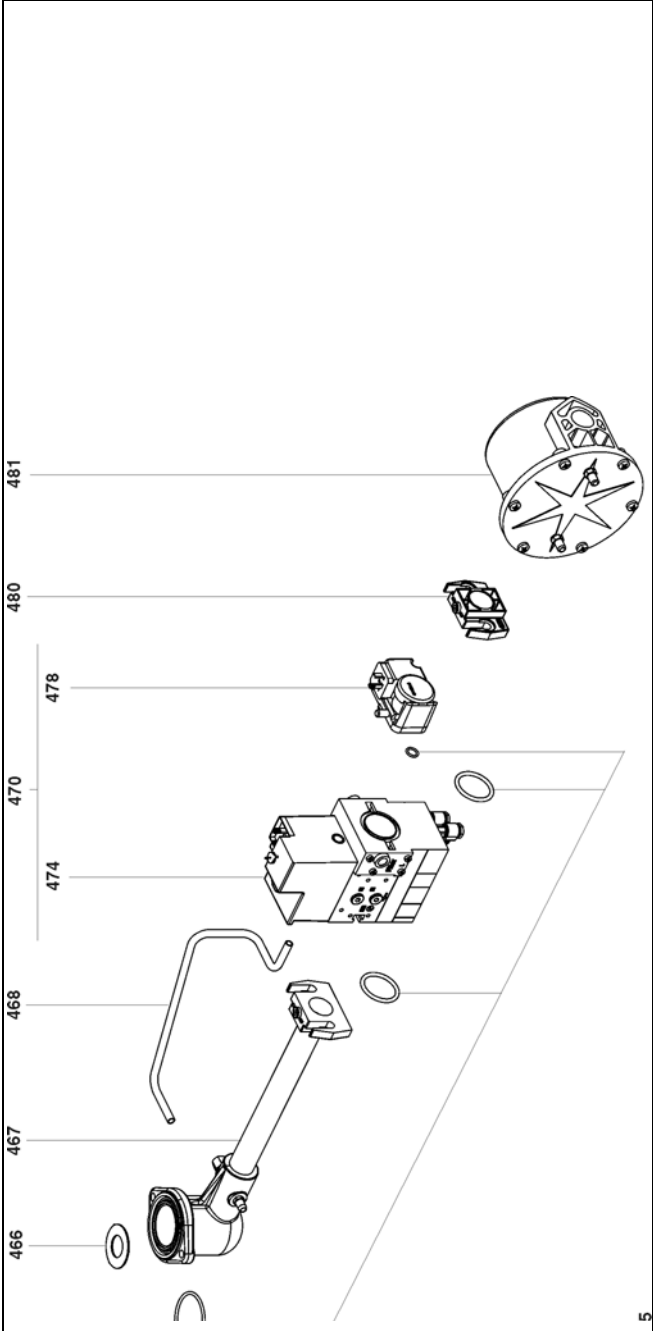

5

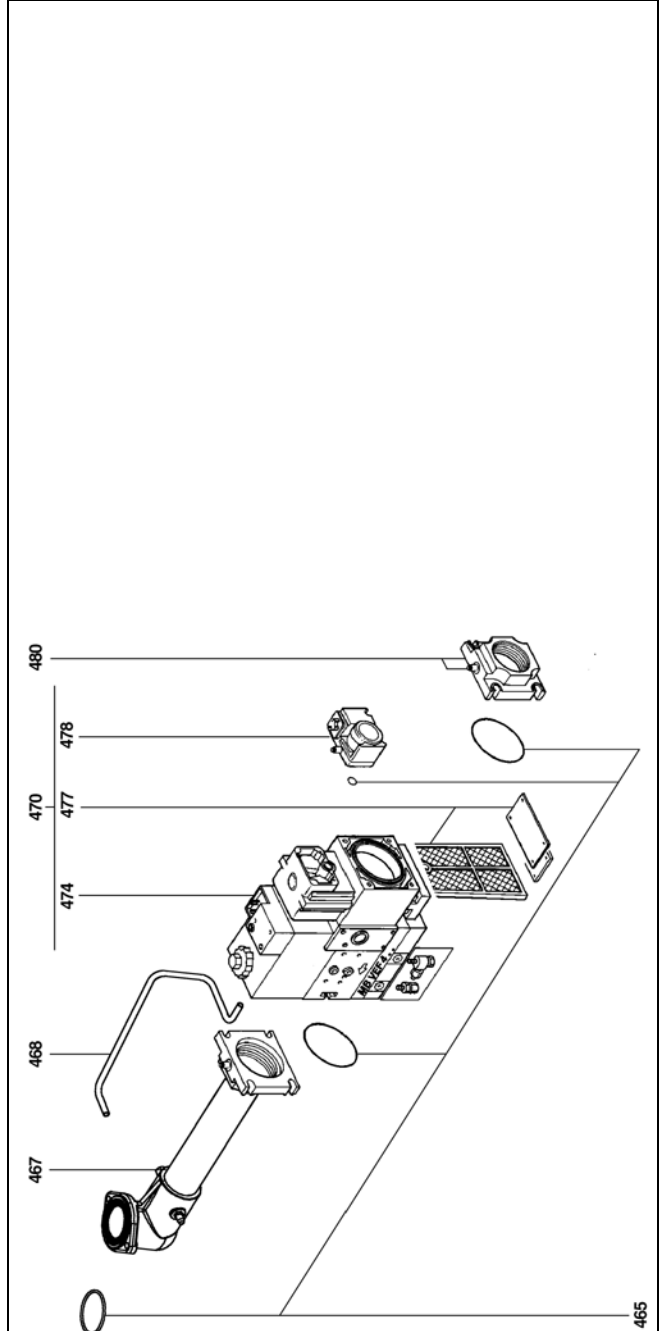

465



Pos.	Désignation	Denominazione	Designación	Description	Bezeichnung	Назначение	N° Art.
400	Rampe gaz	Rampa gas	Rampa de gas	Gas valve assembly	Gasarmatur	Газовая рампа	
1	MBVEF 407						
2	MBVEF 412						
3	MBVEF 420 FI						
4	MBVEF 420 FP						
465	Kit joints O'Ring	Set O'Ring	Kit juntas O'Ring	O'Ring set	O'Ring-set	Кольцо круглого сечения / фланец	
1	MBVEF 407						13 011 313
2	MBVEF 412						13 011 314
3, 4	MBVEF 420						13 016 259
466	Diaphragme	Diaframma	Diafragma	Orifice restricting piece	Blende	Перегородка	
467	Collecteur monté	Collettore	Colector	Gas tube eq.	Gasanschlussrohr Kpl.	Коллектор в сборе	
1	Rp 3/4						
2	Rp 1'1/4						
3, 4	Rp 1'1/2						
468	Tube pression gaz	Tubo pressione gas	Tubo presión gas	Gas pressure tube	Gasrohr	Газовая трубка	
470	Vanne	Valvola	Válvula	Valve	Gasventil	Задвижка основного обмена	
1	MBVEF 407 B01S30						13 016 763
2	MBVEF 412 B01S10						13 016 720
3	MBVEF 420 B01S10 +FI						13 016 723
4	MBVEF 420 B01S10 +FP						13 016 725
474	Bobine VS+ VA	Bobina	Bobina	Magnetic coil	Magnetspule	Катушка	
1	N°1105						13 015 555
2	N°1205						13 015 560
3, 4	N°1215						13 015 561
477	Élément filtrant pour filtre poche	Elemento filtrante per filtro tasca	Elemento filtrante para el filtro bolsillo	Filter medium for pocket filter	Filterelement für Taschenfilter	Фильтрующий элемент встроенного фильтра	13 015 859
478	Pressostat gaz GW150A5	Pressostato gas	Presostato gas	Gas pressure switch	Gasdruckwächter	Газового реле давления	13 016 461
480	Bride/MB	Flangia/MB	Brida/MB	Flange/MB	Flansch/MB	Фланец/МВ	
1	407 Rp 3/4'						13 015 585
2	412 Rp 1'1/4						13 015 586
3, 4	420 Rp 1'1/2						13 015 587
481	Filtre extérieur Rp1	Filtro esterno Rp1	Filtro exterior Rp1	External filter Rp1	ausseres Filter Rp1	Наружный фильтр Rp 1	13 016 006
481.1	Élément filtrant Rp1	Elemento filtrante Rp1	Elemento filtrante Rp1	Filter medium Rp1	Filterelement Rp1	Фильтрующий элемент Rp1	13 015 863





**Schémas électrique et hydraulique**  
**Schemi elettrico e idraulico**  
**Esquema eléctrico y hidráulico**  
**Electric and hydraulic diagrams**  
**Elektro- und Hydraulikschema**  
**Электрические и гидравлические схемы**

**C60 GX507/8**



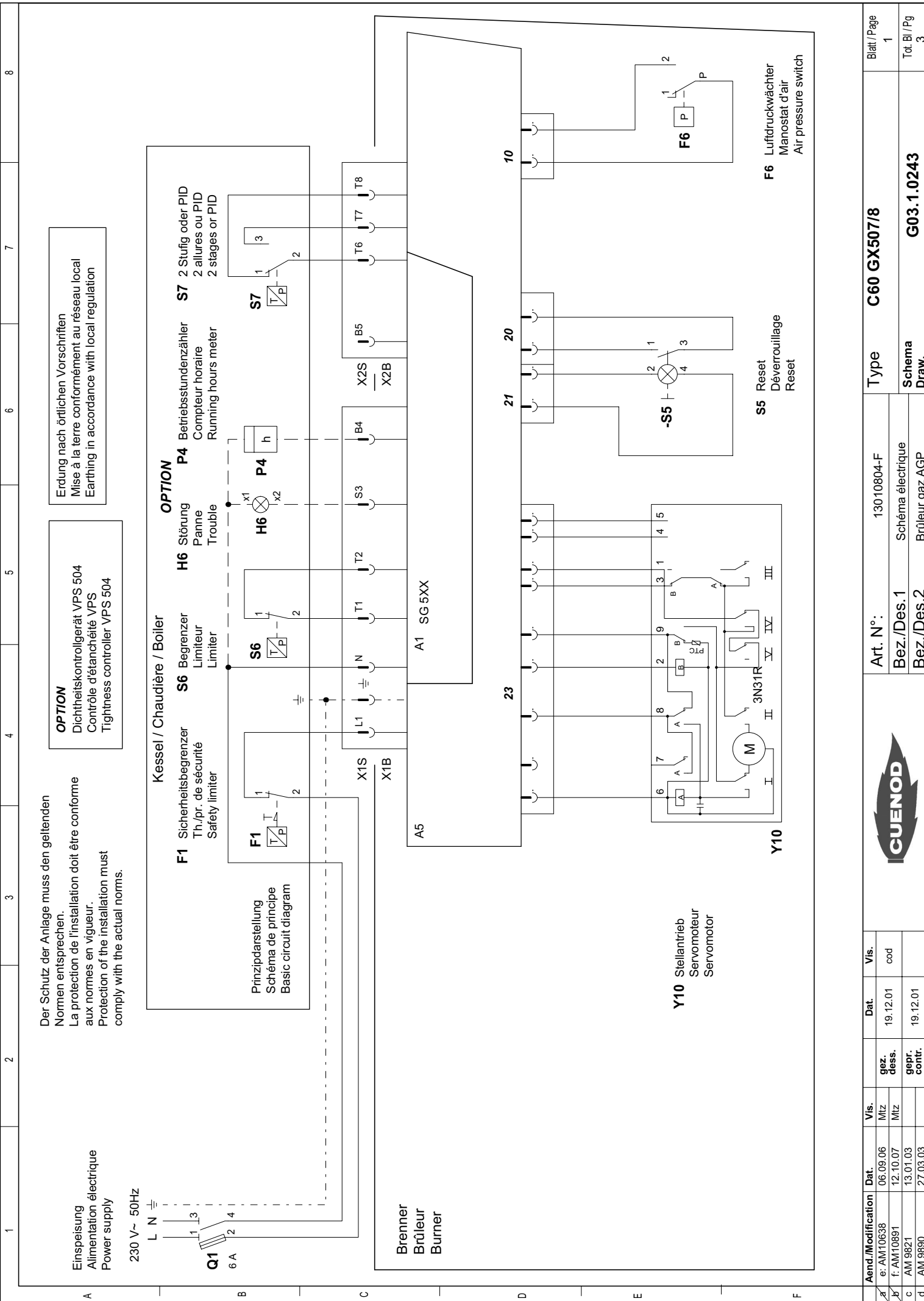

Aend./Modification	Dat.	Vis.	Vis.	Dat.	Vis.	Art. N°:	Type	Blatt / Page
a	06.09.06	MZ		19.12.01	cod	13010804-F	<b>C60 GX507/8</b>	1
b	12.10.07	MZ				Schéma électrique	<b>Schema</b>	Tot. Bl / Pg
c	13.01.03			19.12.01		Brûleur gaz AGP	<b>Draw.</b>	3
d	27.03.03						<b>G03.1.0243</b>	



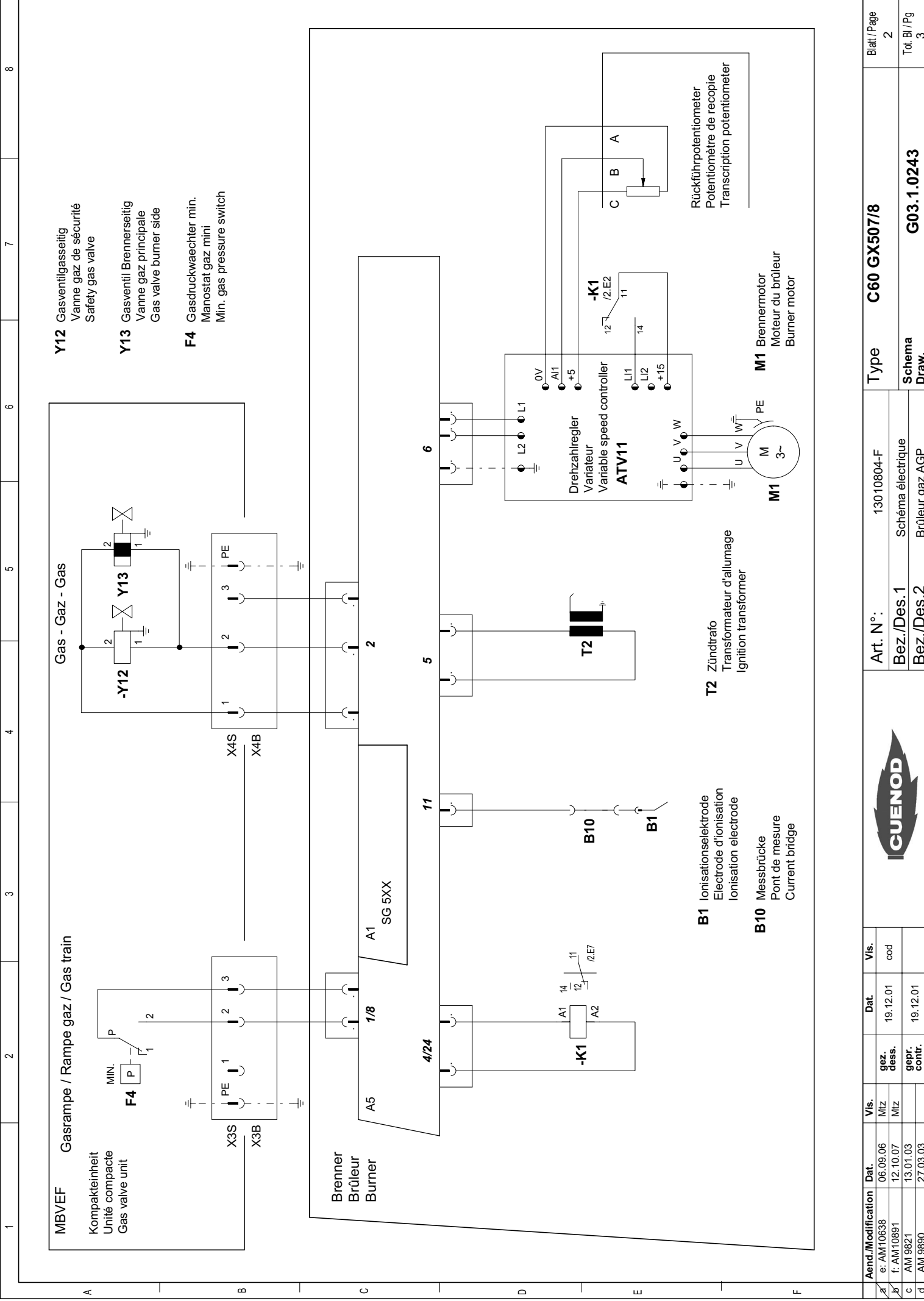

Aend./Modification	Dat.	Vis.	Vis.	Dat.	Vis.
e: AM10638	06.09.06	MZ		19.12.01	cod
f: AM10891	12.10.07	MZ			
c: AM 9821	13.01.03				
d: AM 9890	27.03.03				

Blatt / Page	2
Tot. Bl / Pg	3

A

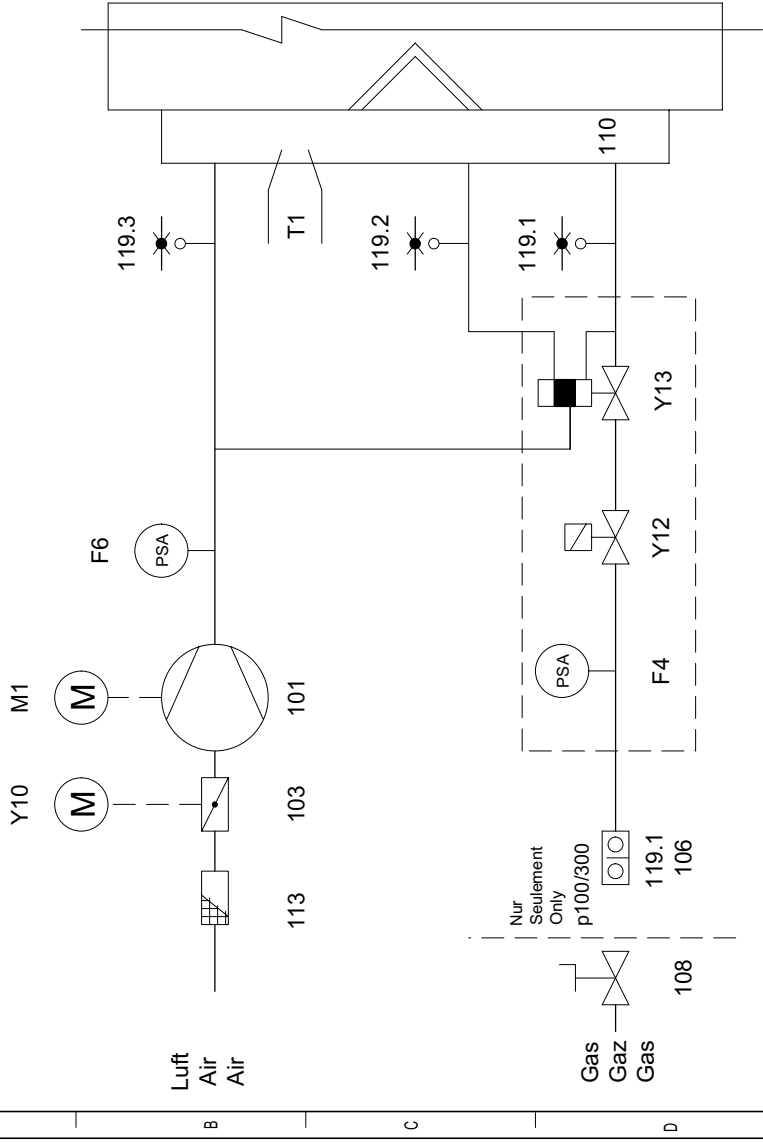

<b>F4</b>	Gasdruckwächter min.	Manostat gaz min.	Min gas pressure switch
<b>F6</b>	Luftdruckwächter	Manostat d'air	Air pressure switch
<b>M1</b>	Brennermotor	Moteur du brûleur	Burner motor
<b>T1</b>	Zündtrafo.	Transfo.	Ignition transfo.
<b>Y10</b>	Stellantrieb	Servomoteur	Damper motor
<b>Y13</b>	Gasventil gassseitig	Vanne gaz principale	Gas valve burner side
<b>Y12</b>	Sicherheitsgasventil	Vanne gaz de sécurité	Safety gas valve
<b>101</b>	Ventilator	Ventilateur	Impeller
<b>103</b>	Luftklappe	Volet d'air	Air-damper
<b>106</b>	Filter	Filter	Filter
<b>108</b>	Handventil	Vanne manuelle quart de tour	Manual valve
<b>110</b>	Gasinjektor	Injecteur gaz	Gas injector
<b>113</b>	Ansauggitter	Grille d'aspiration	Protection
<b>119.1</b>	Messnippel Gas	Prise pression gaz	Pressure pickup Gas
<b>119.2</b>	Messnippel Feuerraum	Prise pression foyer	Pressure pickup furnace
<b>119.3</b>	Messnippel Luft	Prise pression air	Pressure pickup air

Aend./Modification

e	AM10638	06.09.06	Vis.		Dat.		Vis.	
f	AM10891	12.10.07	gez. des.	MZ	19.12.01	cod		
c	AM 9821	13.01.03	gepr. contr.	MZ	19.12.01			
d	AM 9890	27.03.03						

Art. N°: 13010804-F

Bez./Des.1  
Bez./Des.2

Schema hydraulique  
Brûleur.gaz AGP

Type  
Schema Draw.

C60 GX507/8

G03.1.0243

Blatt / Page  
3

Tot. Bl / Pg  
3







---

**CUENOD**  
18 rue des Buchillons  
F – 74100 Annemasse